

# 42-100" Full Motion TV Wall Mount

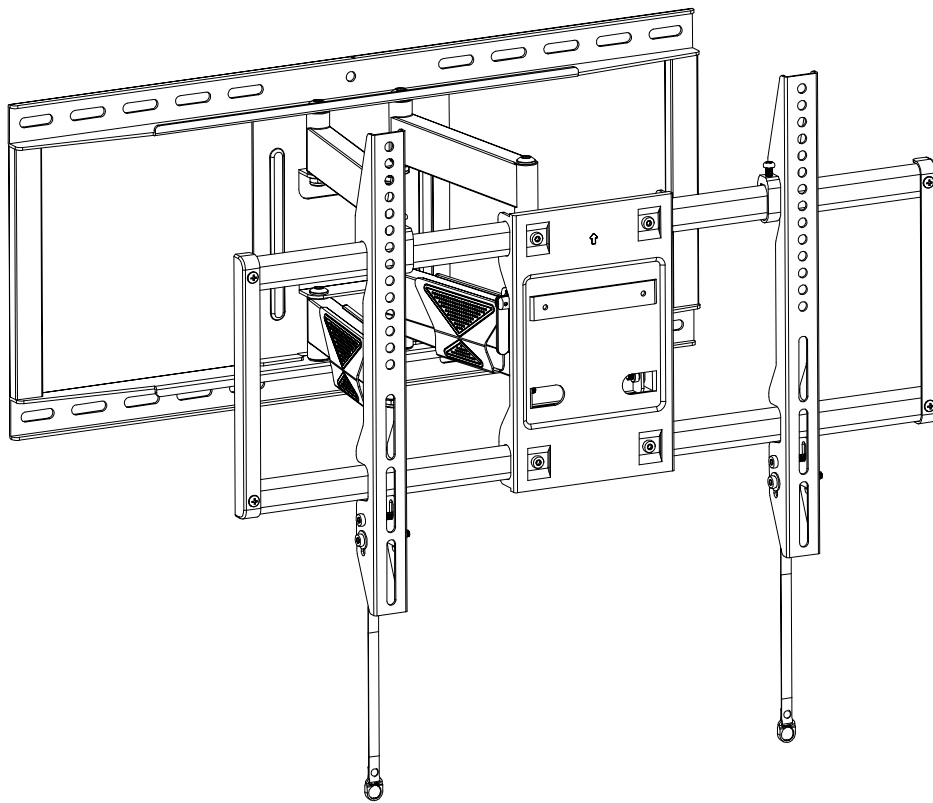

Model: WML018-01

---

**PRODUCT GUIDE**

# DIMENSIONS:

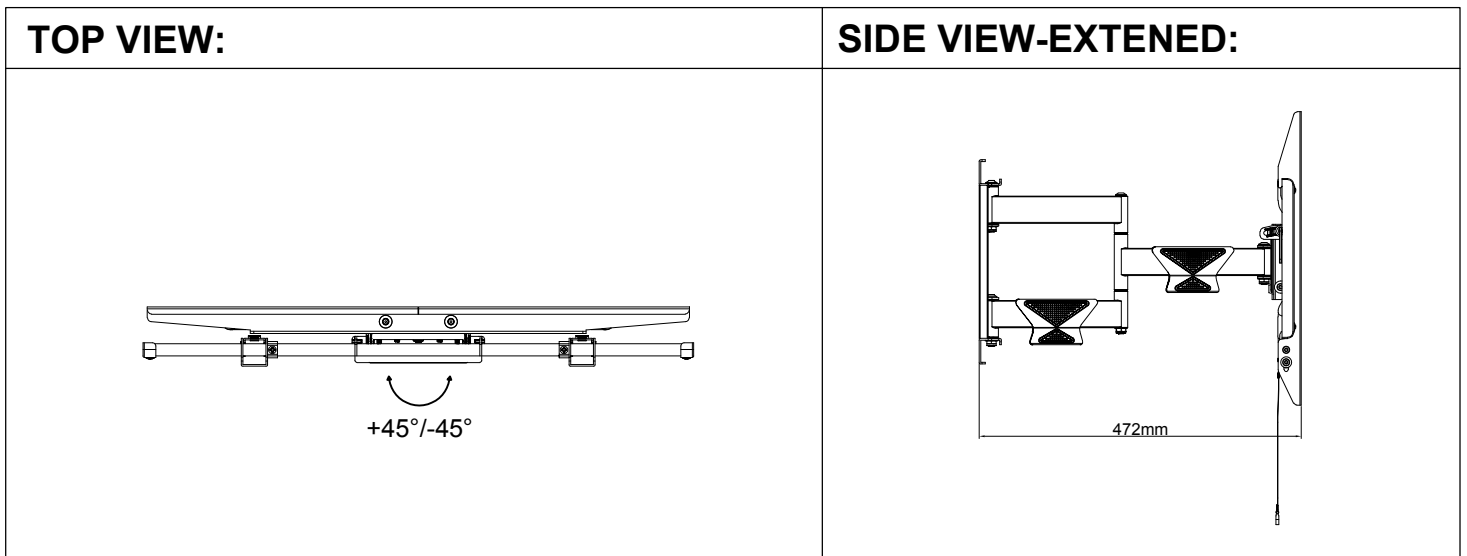
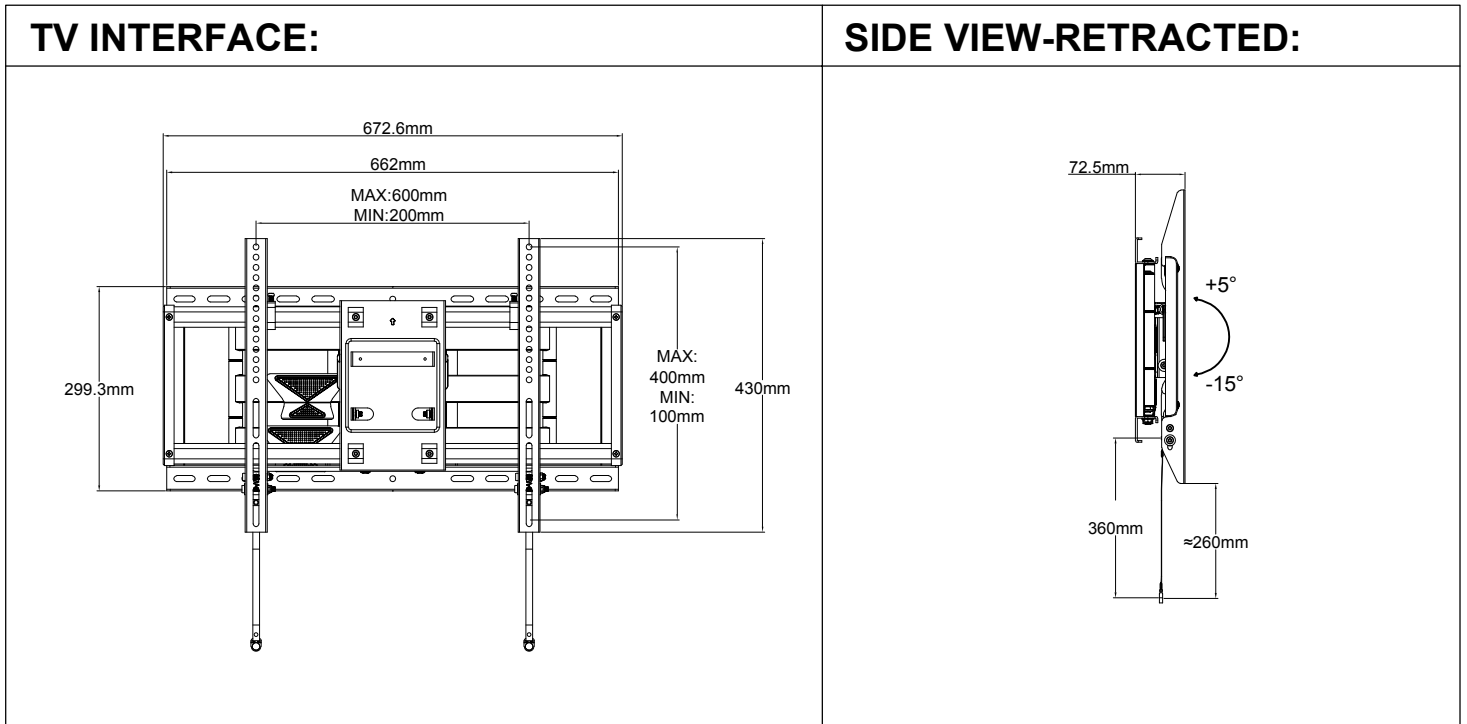

**Congratulations on your latest purchase. Follow these simple instructions and you'll have your TV mounted in no time.**

- Supports most 42 in - 100 in (106.68 cm - 254.00 cm) TVs
- Maximum Weight Capacity: 150 lbs(68 kg)
- Supports VESA Sizes up to 600mmx400mm



If you have any questions along the way, just give us a call 1-800-460-0956 or mail to [customerservice@x-mount.com](mailto:customerservice@x-mount.com). We're ready to help!



## SAFETY WARNING:

- 1.Never let children climb on product or play with product.
- 2.Do not sit or stand on product.
- 3.Do not fasten a TV that is heavier than the recommended load rating to the mount.
- 4.Using suitable concrete wall or wood stud wall.
- 5.Improper installation may cause property damage and/or personal injury, so the installation must be done by two qualified contractors. The manufacture is not liable for damage or injury caused by incorrect mounting, assembly or use.
- 6.Improper handling can result in cuts or lacerations.

## ASSEMBLY TIPS:

- 1.Become familiar with the instructions and all parts.
- 2.Make sure that all parts are in the box and in good condition.
- 3.Assemble the product on the open flat carton or a rug to protect the product and your floor.
- 4.Some heavy products need a second person to assist in the assembly. Do not install on sloping surface.

**▲ CAUTION :** This mount is intended for use with TV weights not exceeding " maximum weight capacity 150 lbs." The wall itself has to be capable of supporting 4 times standard weight. Please don't over tighten screws in order to avoid any injury. Use with products heavier than the maximum weights indicated may result in collapse of the mount and its accessories causing possible injury.

### ● Parts list:

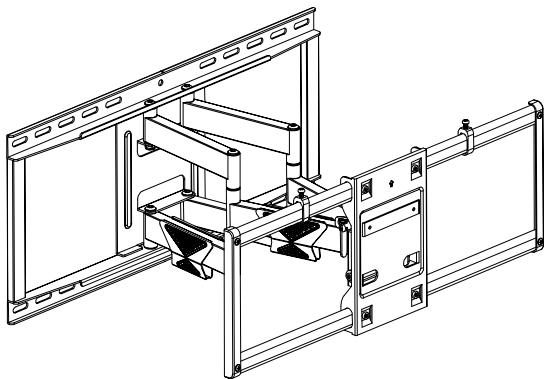

A--Wall plate  
1pc



B--Bracket  
2pcs

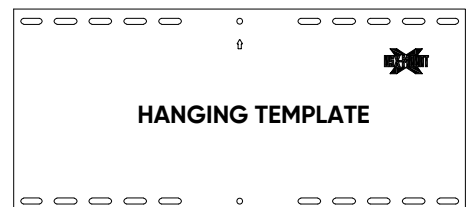





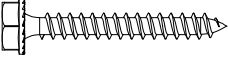
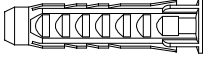
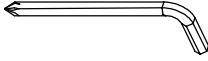
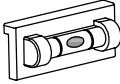





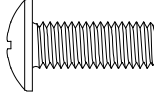

Hanging template  
1pc

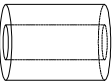
## ● Wall mounting and TV bracket assembly hardware:

|   |   |   |   |
|---|---|---|---|
|  |  |  |  |
| C--Lag bolt<br>4pcs   | D--Anchor<br>4pcs   | E--Allen key<br>1pc   | F--Bubble Level<br>1pc  |

## ● TV mounting hardware:

|   |   |   |  |   |   |
|---|---|---|--|---|---|
|  |  |  |  |  |  |
| a--M4x12 screw<br>4 pcs   | b--M6x12 screw<br>4 pcs   | c--M8x25 screw<br>4 pcs   | d--M4x30 screw<br>4 pcs  | e--M6x35 screw<br>4 pcs   | f--M8x45 screw<br>4pcs  |
|  |  |  |   |  |  |
| g--M8 spacer<br>4pcs  | h--10mm spacer<br>4pcs  | i--2.5mm spacer<br>8pcs   | j--M6 spacer<br>4pcs   | k--M4 washer<br>4pcs  | l--M6 washer<br>4pcs  |

### Step 1: Install wall plate on the wall.

**For concrete wall:** Hold hanging template against wall at desired position on concrete wall, then using a pencil mark 4 hole locations. Then drill holes according pencil marks using 3/8" size drill bit to a depth of 2.5". Please remove the hanging template on the surface of concrete wall when assembling mount on the concrete wall. Then you will need to use wall anchors (D). Insert wall anchors (D) into holes, you may need to use hammer to lightly tap wall anchors into wall. Then fix wall plate unit (A) to the wall with lag bolts (C). (Figure 1)

**CAUTION:** The concrete wall minimum thickness no less than 8 inches, and surface covering can't more than 3/8 inches.

**CAUTION:** Don't use anchor on the concrete block.

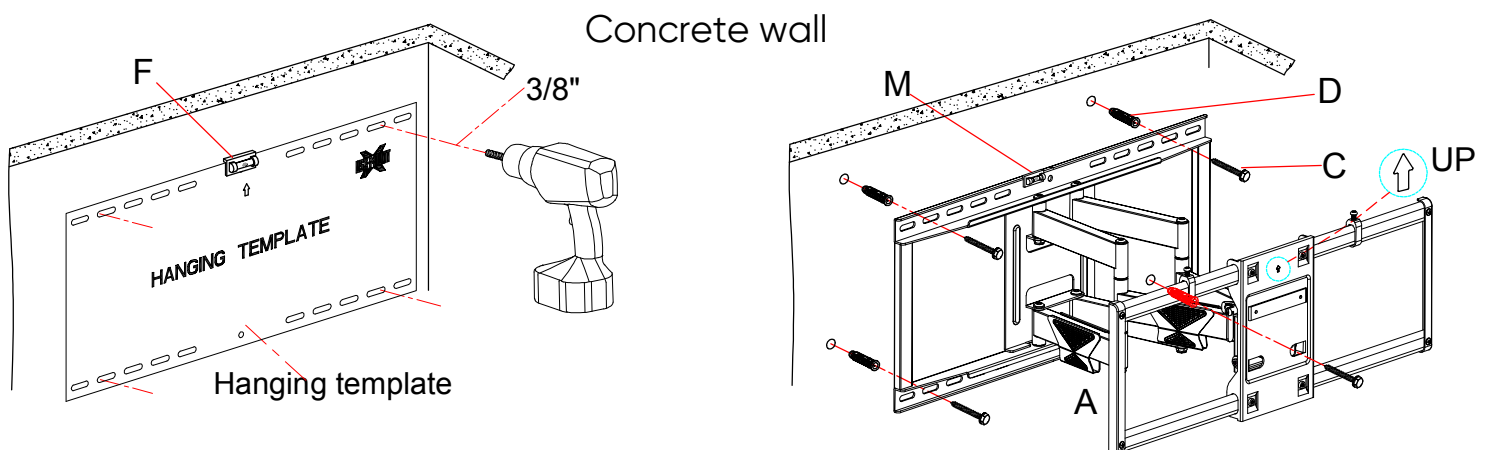

Figure 1 (keep the wall plate level)

**For wood studs:** If you mount TV mount into wood studs, hold mounting template at desired position of wood stud, pre-drill the mark 4 holes using 7/32" drill bit to a depth of 2.5", fix wall plate unit (A) to the wall with lag bolts (C). (Figure 2)

NEVER USE ANCHOR (D) FOR WOOD STUDS ASSEMBLY

**▲ CAUTION:** The wood stud min size is 2x4 inches, and surface covering can't be more than 5/8 inches. Drill hole on the wood stud middle line.

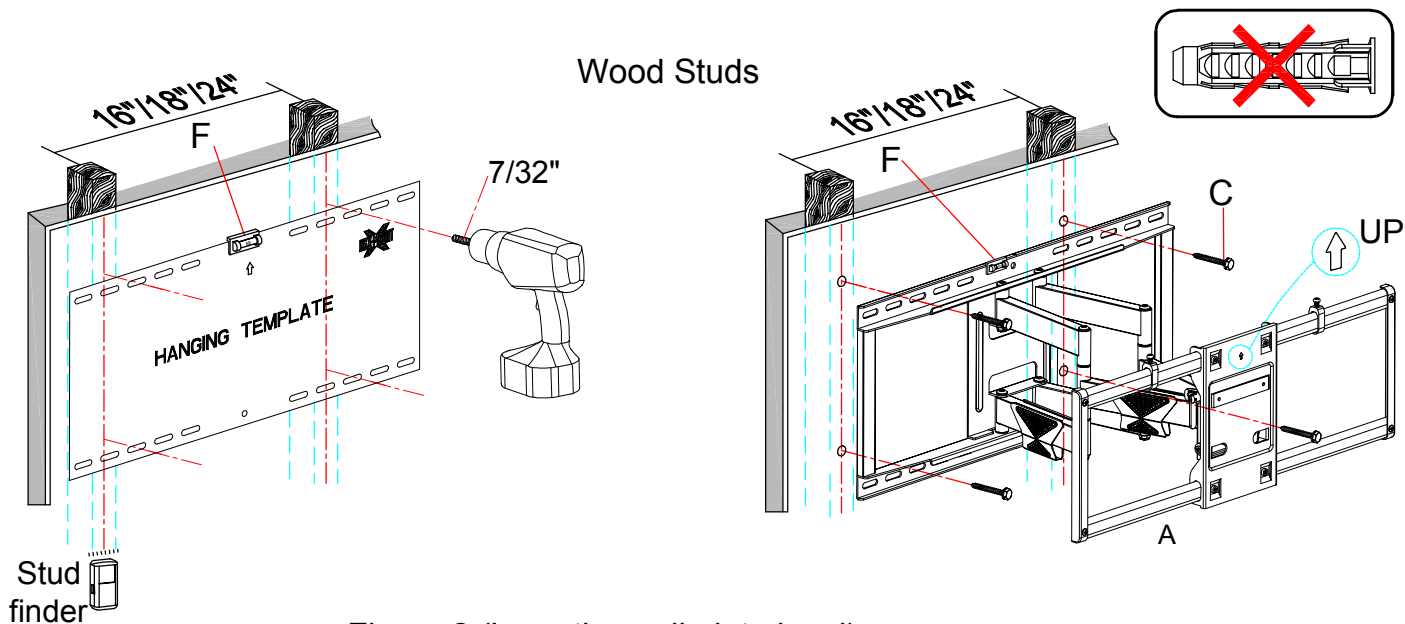

Figure 2 (keep the wall plate level)

**Step 2:** Attach bracket (B) to the back of TV, choose corresponding screw, washer, spacers to fix the holes of TV rear. (Figure 3)

**▲ CAUTION:** Using incorrect spacers may damage your TV.

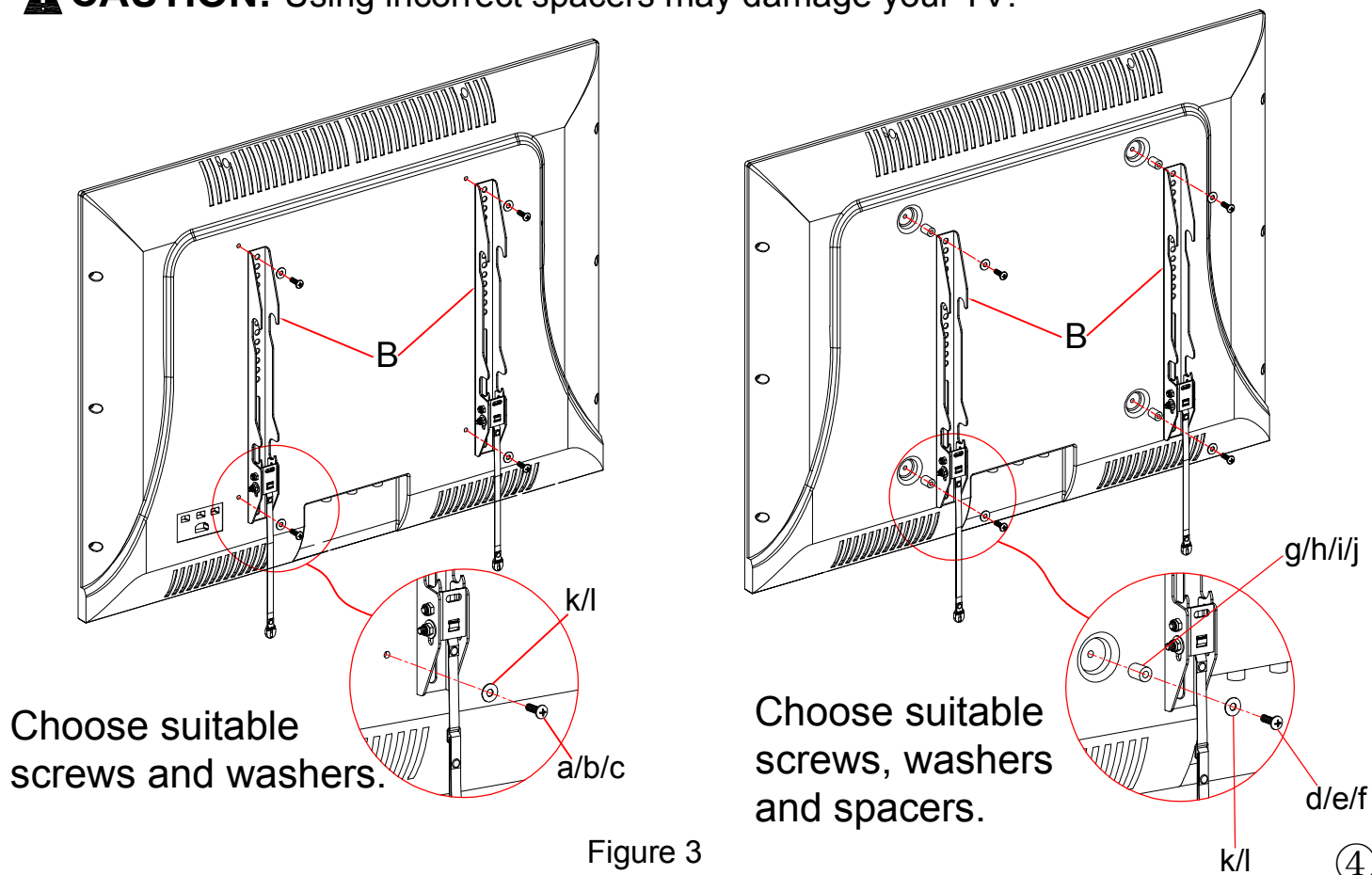

Figure 3

**Step 3:** Hang the pre-assembled TV unit onto the horizontal bars of the wall plate unit.  
Pull down straps to lock the brackets in the bar (Figure 4).

**CAUTION:** This step must require 2 or more people to finish.

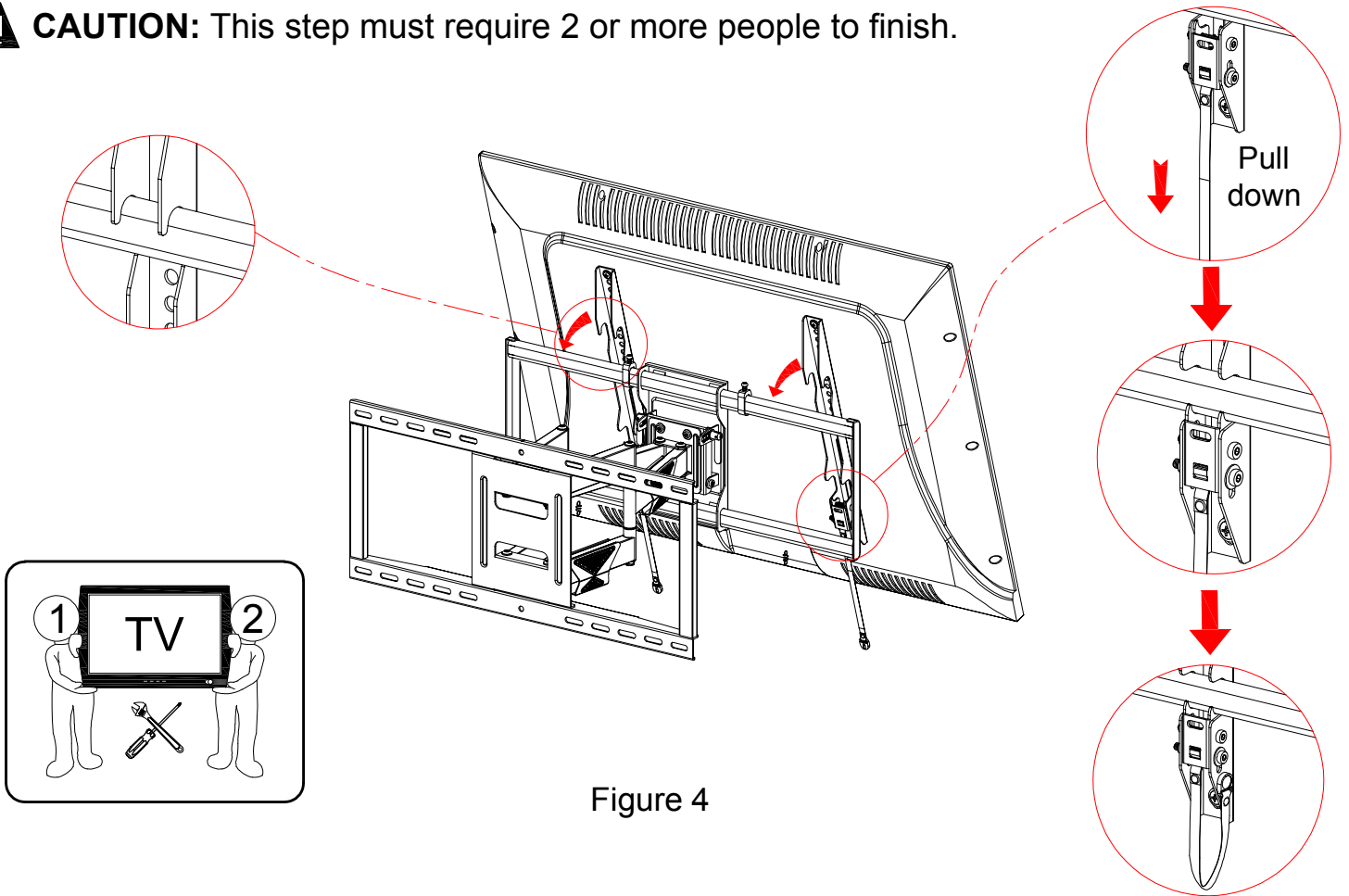

Figure 4

**Step 4:** Move the fixed block close to brackets, then fasten the screws with screwdriver to ensure the brackets unmovable. (Figure 5)

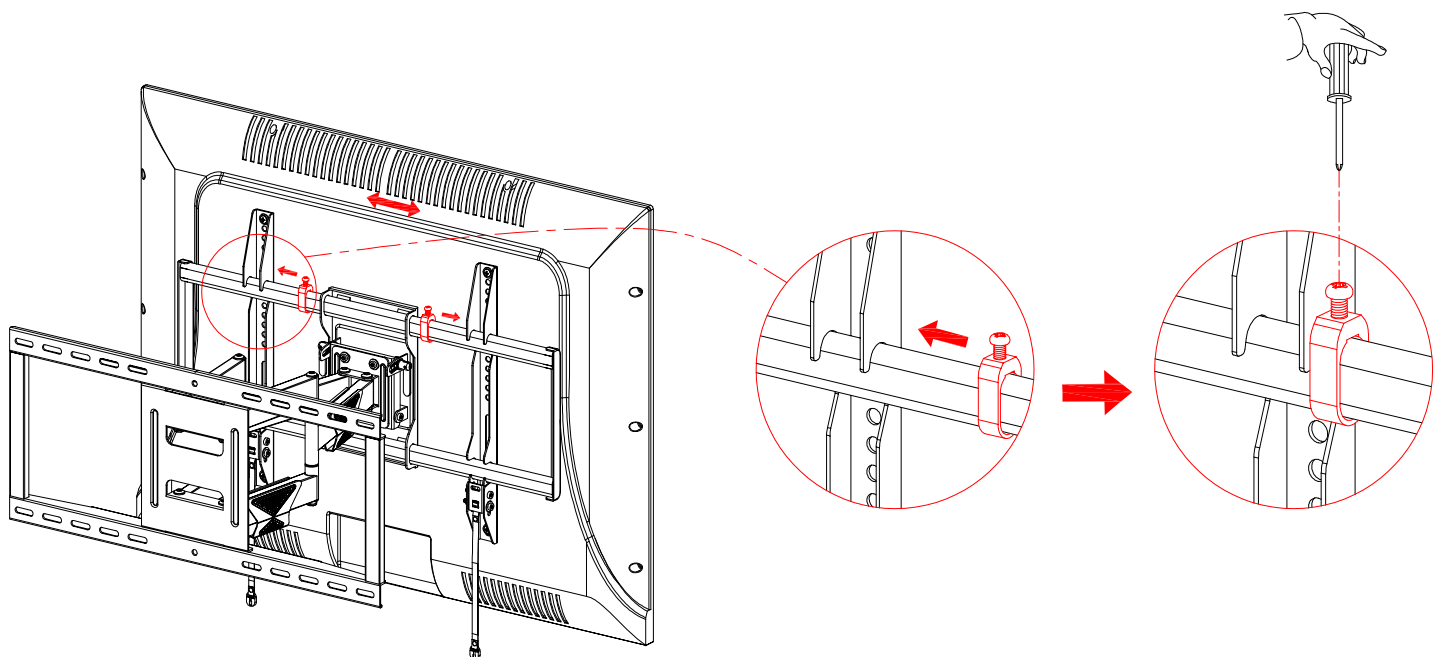

Figure 5

**Step 5:** Make sure the TV unit is horizontal, you can adjust the TV plate a little bit (+3/-3 degrees) to level the TV, then fasten TV plate by bolts with Allen key (E). (Figure 6)

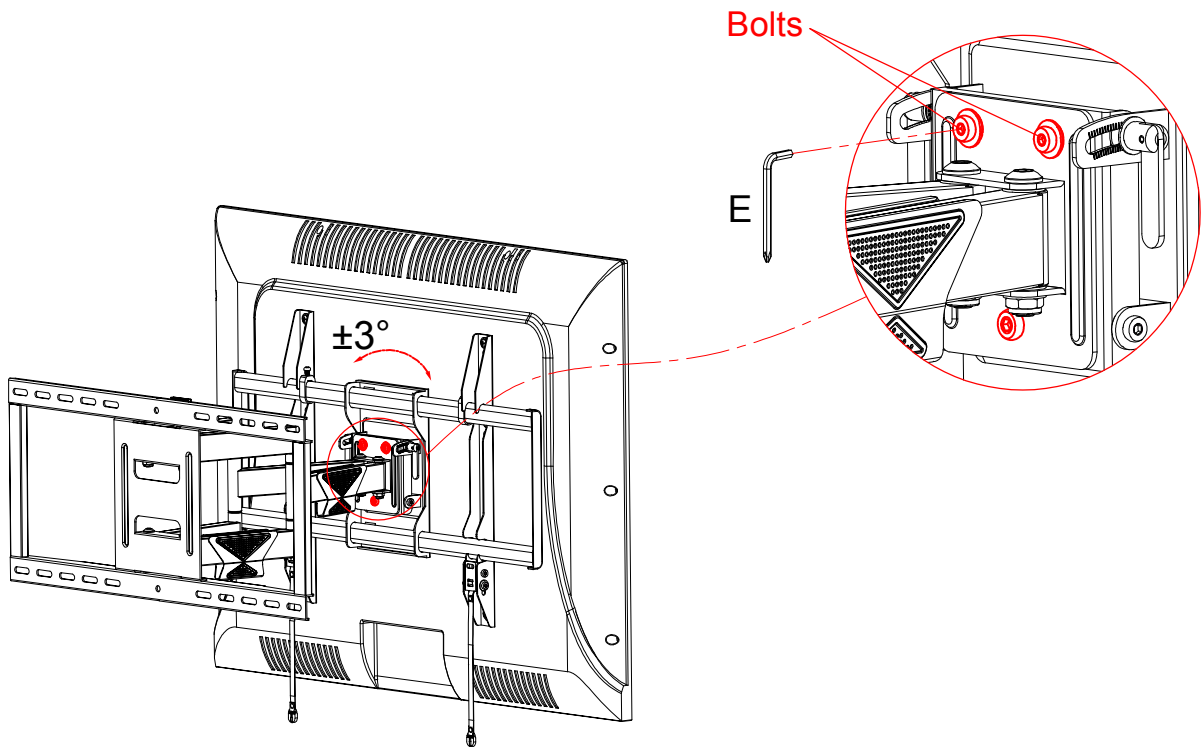

Figure 6

**Step 6:** You may need loosen the handle to tilt TV to your desired angle, please remember to fasten the handle tightly after adjustment. (Figure 7)

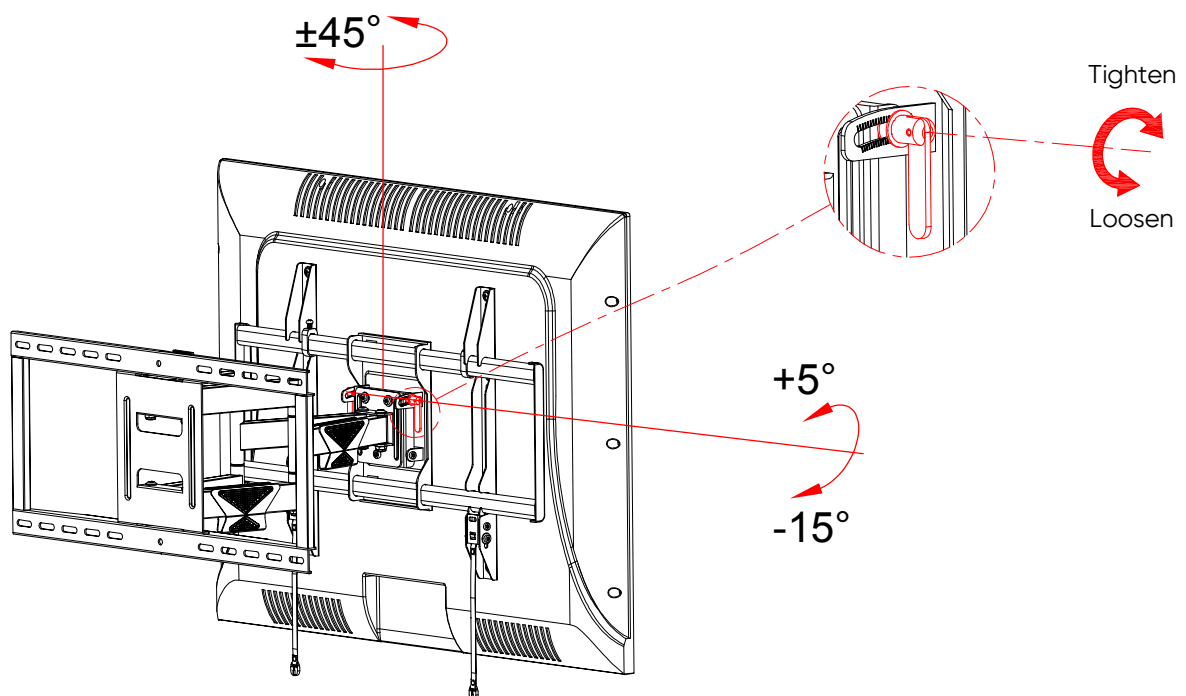

Figure 7

**Step 7:** Manage TV cables orderly and guide them through the velcros. (Figure 8)

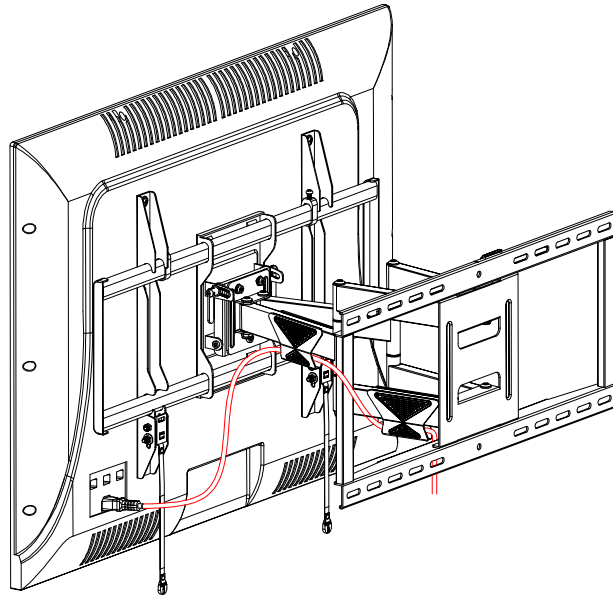

Figure 8

**PAY EXTRA CARE AND ATTENTION WHEN YOU FASTEN TWO TV BRACKETS TO THE BACK PANEL OF TV IN STEP 2 . MAKE SURE THE APPROPRIATE MOUNT HARDWARE IS BEING USED PROPERLY .**

1. Select correct Mounting Hardware according to the screw hole size of your TV, discard any remaining screws or spacers.
2. Carefully lay your TV on its face on a non-abrasivesurface, making sure to lay padding underneath it so as not to damage the screen .
3. Place left TV bracket and right TV bracket in the appropriate position, making sure **CENTERED** on the back of the TV and **LEVEL** with on another .
4. This product only install on the perpendicular wall,not install on the ceiling.